

T 60/80/100 MS

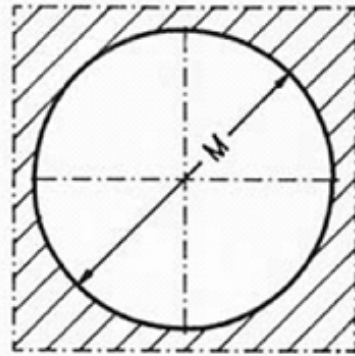
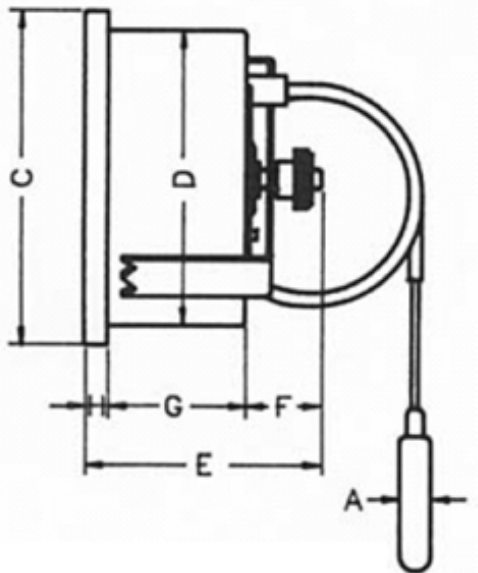

A
Ø 6 mm
Ø 6,5 mm
Ø 8,5 mm
Altri su richiesta other on request

	C	D	E	F	G	H	M
Ø 63	68	62	47	15	27	5	61
Ø 80	86	80	32		27	5	81
Ø 100	105	100	32		27	5	101

Case and glass cover retaining ring: AISI 304 stainless steel.

Fixing system: metallic bracket. Glass cover: shatterproof metacrylate ester.

Capillaries: bare or coated copper (usually black PVC on instruments for heating applications, white polypropylene for refrigeration, copper braid for higher temperatures, for example 50/350°C); standard lengths 0,5 - 1 - 1,5 metres, other lengths on request.

Bulb: brass; look at the table for available types, other on request. Movement: phosphor bronze tube spiral.

Dial: printed aluminium. Custom designed dials can be supplied.

Scales: -40/+40°C for refrigeration, 0/120°C and 50/350°C for heating; other scales on request. Accuracy: ± 3% of highest value.